



tesa[®]

PREVENTION, PROTECTION AND SECURING

Adhesive Tape Solutions for the Food Industry



YOUR PARTNER FOR FOOD PACKAGING

Choosing the right food packaging is the key to protecting and maintaining food. This is also the most reliable way to control and protect food against biological and physical factors. From solutions for single- and double-sided bag reclosure, to bag and candy cup sealing, innovative carton box closures, and palletizing, we provide a full assortment for the global packaged consumer goods industry.

As a global partner to various food industry enterprises, we offer a wide range of food packaging assortments to match the needs of individual customers for both inner and outer packaging.

The innovative solutions of our inner packaging prevent food from spoiling, making consumption easy, and pleasant. Our robust solutions also enable designs that help increase consumer brand engagement by allowing consumers to use the original packaging after opening the product. Just as critical as the inner packaging is the outer packaging. Our outer packaging solutions provide a full assortment of packaging tapes to protect products when exposed to critical environmental conditions during storage and transportation. Convenient packaging solutions have been identified as a key factor in the consumer's product selection process; do not leave the packaging to chance.

Contents

Category	Page
Inner packaging	4
Resealable bag closure single-sided solutions	5
Resealable bag closure double-sided solutions	6
Bag sealer	8
Sealing of candy cups	9
Handylift	10
Outer packaging	11
Carton sealing	12
Frozen food boxes	14
Knifeless box opening	16
Palletizing of cartons	17
Dispenser	18
Dispenser for bag sealing	19
Dispenser for carton sealing	20



INNER PACKAGING

Our Products for Inner Packaging Applications

Inner packaging applications require the most attention, as your end customers are in direct contact with them. Therefore, they need products that provide secure packaging, while offering attractive and convenient handling or resealing of your product's packaging. Whether they require a food safe approval for indirect food contact or other special

requirements, we are looking forward to providing you with distinguishable inner packaging solutions. For example, with our single- and double-sided bag reclosure solutions, your product packaging will be safe and convenient for end customers.

RESEALABLE BAG CLOSURE SINGLE-SIDED SOLUTIONS

Solution for Convenient Reclosure

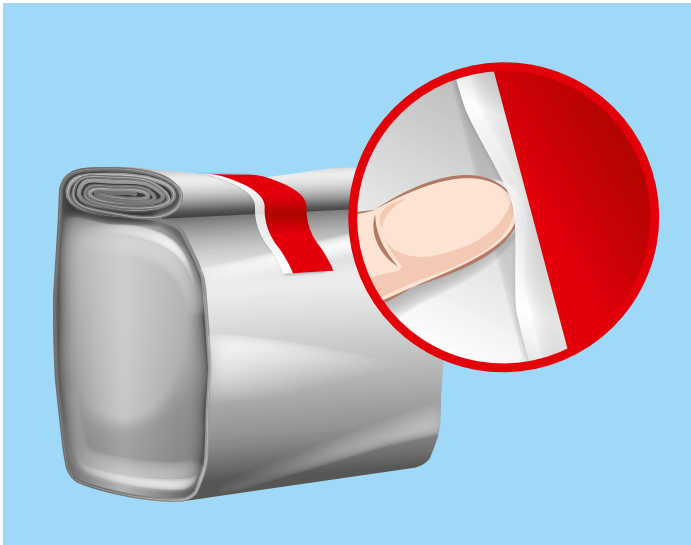

tesa® Lift & Reseal

Our tesa® Lift & Reseal single-sided resealable bag closure system offers approximately 20 effective reclosure actions, giving consumers the ability to reseal the pack for the lifetime of its contents. Alongside the possibility of adding value to your end product, tesa® Lift & Reseal is developed to be easily integrated into the packaging process. Whether you are packing nuts, snacks, fruits, or vegetables, tesa® Lift & Reseal is a convenient reclosure solution to keep them fresh.

Features of tesa® Lift & Reseal

- High-tack tape with good shear strength, enabling effective reclosure that will not pop open
- Robust and stable adhesive – no residues, good aging resistance
- Custom printed fingerlift strip for easy peel back
- Supplied spool wound, for rapid integration on the production line
- A full and complete solution including the tape and a tesa® 6081 dispenser, with no impact on your running speed

tesa® 6081

Spool dispenser with brake and buffer system

- Unwind tape from spools in a controlled way. Guide the tape precisely and without damage to the lamination unit
- The brake and buffer system allows a high lamination speed and compensates for variations in line speed due to cutting processes, etc.
- Easy operation and little set-up time translates into efficient processes

Main applications

Many customers worldwide have proven the reliable taping process. Commonly used by producers of aluminium profiles, MDF trims, and magnetic strips.



Technical properties	tesa® 6081
Core diameter	6 inch
Length	900 mm
Width	450 mm
Height	700 mm
Weight	22000 g
Type of applicator	Machine

RESEALABLE BAG CLOSURE DOUBLE-SIDED SOLUTIONS

Solution for Convenient Reclosure

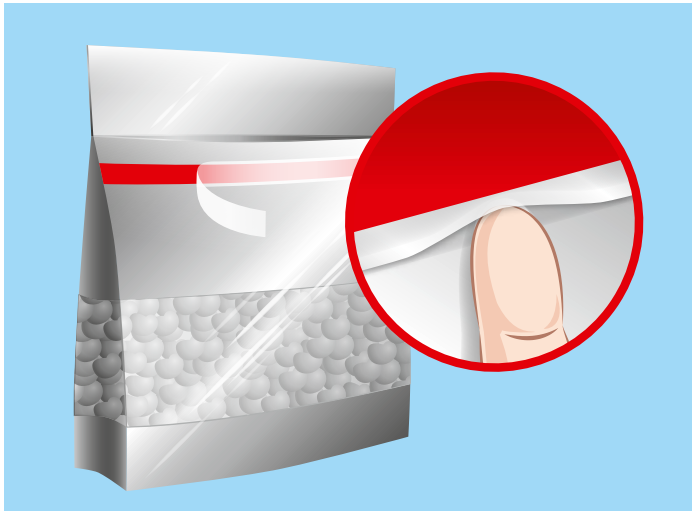

Depending on your production requirements, we offer you a full assortment of different double-sided resealable bag closure solutions. The main advantage of our reclosure tapes is the long-lasting freshness achieved by its tight closure. All products are available with and without a liner with overhanging fingerlift, which offers convenient liner removal. Our product alternatives enable that we can offer a suitable solution for all kinds of bags.

Features of our double-sided resealable bag closures

- Strong and stable acrylic or synthetic rubber adhesive
- No residues, excellent aging resistance
- Extended fingerlift liner available for easy liner removal
- Supplied spool wound, for rapid integration on the production line

tesa® 4917

Double-sided filmic tape with differential adhesive system, without fingerlift

tesa® 4917 consists of a transparent double-sided PP film with a differential adhesive system. The product can easily be cut with the hot wire systems of common bag machine producers.

Main applications

- Reopenable closure system for filmic bags
- Removable emblems or profiles

tesa® 6917

Double-sided filmic tape with differential adhesive system and fingerlift

tesa® 6917 has been designed for resealable filmic bags. It consists of a transparent double-sided PP film with a differential adhesive system. The product can easily be cut with the hot wire systems of common bag machine producers. tesa® 6917 comes with fingerlift (extended liner) for convenient liner removal.

Main applications

- Reopenable closure system for filmic bags
- Removable emblems or profiles

tesa® 64621 PV0

Double-sided filmic tape with and without fingerlift

tesa® 64621 PV0 is a transparent double-sided self-adhesive tape consisting of a PP backing and a synthetic rubber adhesive (SIS). tesa® 64621 PV0 is solvent-free and offers a very high tack.

Main applications

- Reopenable closure system for filmic bags
- General purpose fixing tape
- Self-adhesive mounting of decorative and packaging materials
- Bonding of foils, fabrics, paper, and plastic materials

tesa® 64621 PV6

Double-sided filmic tape with fingerlift

Stable red filmic liner of tesa® 64621 PV6 leads to an easy automatic application process. A long spool length of 8000 m leads to fewer machine stops and contributes to an efficient production process. The translucent tesa® 64621 PV6 liner can show written instructions on food packaging.

Main applications

- Reopenable closure system for filmic bags
- General purpose fixing tape
- Self-adhesive mounting of decorative and packaging materials
- Bonding of foils, fabrics, paper, and plastic materials

Find the right resealable double-sided bag closure option

Technical properties	tesa® 4917	tesa® 6917	tesa® 64621 PV0	tesa® 64621 PV6
Tape				
Backing material	PP film	PP film	PP film	PP film
Total thickness	90 µm	90 µm	90 µm	90 µm
Type of adhesive	Tackified acrylic	Tackified acrylic	Synthetic rubber	Synthetic rubber
Adhesion to steel (after 14 days)	11.4 N/cm	11.4 N/cm	15.0 N/cm	15.0 N/cm
Adhesion to PE (after 14 days)	4.1 N/cm	4.1 N/cm	6.5 N/cm	6.5 N/cm
Temperature resistance (short term)	120°C	120°C	80°C	80°C
Temperature resistance (long term)	80°C	80°C	40°C	40°C
Differential adhesive	Yes	Yes	No	No
Tack	●●●	●●●	●●●●	●●●●
Aging resistance (UV)	●●●●	●●●●	●●	●●
Humidity resistance	●●●●	●●●●	●●●	●●●
Static shear resistance at 23°C	●●●	●●●	●●	●●
Static shear resistance at 40°C	●●●	●●●	●	●
Color	Transparent	Transparent	Transparent	Transparent
Type of liner	PP	PP	Glassine paper	PP
Color of liner	Red	Red	Yellow	Red
Fingerlift	No	Yes	Yes/No	Yes
Thickness of liner	80 µm	80 µm	70 µm	80 µm

Evaluation across relevant tesa® assortment: ●●●● Very good ●●● Good ●● Medium ● Low

BAG SEALER

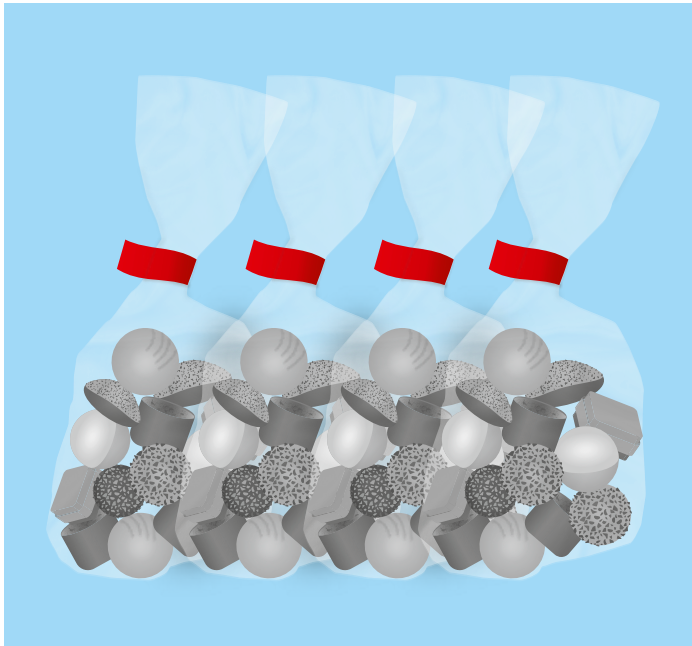

Secure Closure with Bag Sealing Tapes



Bakery products, candies, and other consumables that are packed in bags require a reliable closure. With our bag sealing tapes we offer suitable solutions here. Furthermore, we provide supplementary dispensers for efficient operations.

Features of our bag sealer

- For sealing small boxes and cans
- Use at bakery and flower shop counters
- Available in transparent and different colors
- A full and complete solution including the tape and a tesa® 6094 dispenser

Tape	Product description and application	Main application	Backing	Adhesion to steel [N/cm]	Total thickness [μm]	Tensile strength [N/cm]	Elongation at break [%]	Color
			Adhesive		Backing thickness [μm]			
	tesa® 4204 PV0 Colored filmic packaging tape tesa® 4204 PV0 is based on a stable PVC backing coated with a natural rubber adhesive. This product can generally be used on all common desk dispensers.	<ul style="list-style-type: none"> • Sealing small boxes and cans • Use at bakery and flower shop counters • Suitable for marking based on the variety of colors 	PVC film	2.0	59	50	75	<ul style="list-style-type: none"> ○ White* ● Red ● Yellow ● Blue ● Green ● Havana* ○ Trans-parent*
			Natural rubber		32			
	tesa® 4205 Transparent small item packaging tape tesa® 4205 is based on a 28 μm PP backing coated with a natural rubber adhesive. This product design provides good properties for sealing applications of small items. tesa® 4205 can be used on all common desk dispensers.	<ul style="list-style-type: none"> • Sealing of small boxes or cans • Bundling of small items 	PP film	2.5	45	43	145	○ Trans-parent
			Natural rubber		28			

* tesa® 4204 white, havana, and transparent have other technical data.

SEALING OF CANDY CUPS

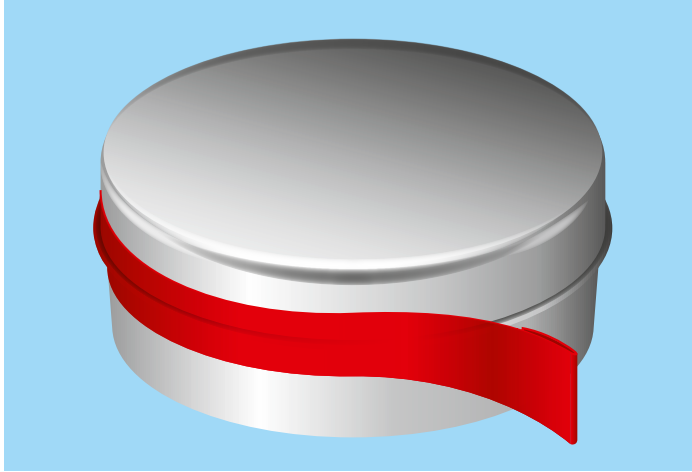

Colorful Solutions for Sealing Candy Cups



Classic candy tins must be sealed with a layer of adhesive tape. We offer reliable solutions for their closure during transportation until they reach the end customer. Our transparent versions are most commonly used in this application, but we also offer a wide range of colors.

Features of candy cup sealing

- Sealing small boxes (cardboard or plastic)
- Sealing tins and bags
- Available in transparent and different colors
- tesa® 4104 red enables sharp-edge masking for multicolor painting

Tape	Product description and application	Main application	Backing	Adhesion to steel [N/cm]	Total thickness [µm]	Tensile strength [N/cm]	Elongation at break [%]	Color
			Adhesive		Backing thickness [µm]			
	tesa® 4104 colored Brilliant colored filmic packaging tape tesa® 4104 is a premium packaging tape based on a PVC-film backing and a natural rubber adhesive. It shows excellent performance on all kinds of cardboards and secures a safe closure.	<ul style="list-style-type: none"> • Sealing small boxes (cardboard or plastic) • Sealing tins and bags • Variety of colors available make tesa® 4104 ideal for marking 	PVC film	3.6	67	60	60	<ul style="list-style-type: none"> ● Black ○ White ● Red ● Orange ● Yellow ● Blue ● Green
			Natural rubber		40			
	tesa® 4204 PVO Colored filmic packaging tape tesa® 4204 PVO is based on a stable PVC backing coated with a natural rubber adhesive. This product can generally be used on all common desk dispensers.	<ul style="list-style-type: none"> • Sealing small boxes and cans • Use at bakery and flower shop counters • Suitable for marking based on the variety of colors 	PVC film	2.0	59	50	75	<ul style="list-style-type: none"> ○ White* ● Red ● Yellow ● Blue ● Green ● Havana* ○ Trans-parent*
			Natural rubber		32			
	tesa® 4205 Transparent small item packaging tape tesa® 4205 is based on a 28 µm PP backing coated with a natural rubber adhesive. This product design provides good properties for sealing applications of small items. tesa® 4205 can be used on all common desk dispensers.	<ul style="list-style-type: none"> • Sealing small boxes and cans • Bundling of small items 	PP film	2.5	45	43	145	<ul style="list-style-type: none"> ○ Trans-parent
			Natural rubber		28			

* tesa® 4204 white, havana, and transparent have other technical data.

HANDYLIFT

Carrying Handle for Convenience





While carrying water bottles or other products with a high weight, a strong and comfortable handle tape is required. Our tesa® handylift offers you an efficient solution that allows you to run a fast production process while reducing downtime. This high-quality product is suitable on almost all kinds of wrapping material, ensuring a reliable bond.

Our tesa® handylift product consists of a strong MOPP tape (Mono-axially Oriented Polypropylene) with an laminated, non-sticky, and printable foam, foil, or paper.

Features of handylift

- Pre-material for carry handles
- Applicable for weights up to 18 kg
- High-quality natural rubber adhesive
- Handle can be custom printed

Tape	Product description and application	Main application	Backing	Adhesion to steel [N/cm]	Total thickness [μm]	Tensile strength [N/cm]	Elongation at break [%]
			Adhesive				
	tesa® 64285 Tensitized polypropylene tape tesa® 64285 is a tensitized polypropylene tape with a natural rubber adhesive. It exhibits good tensile strength with low elongation at the same time. The product is especially recommended for handylift applications. It provides residue-free removal and no discoloration.	<ul style="list-style-type: none"> • Pre-material for handylift • Palletizing, adhering, or bundling are also possible 	MOPP	4.0	72	180	35
			Natural rubber				
	tesa® 64286 Strapping tape for basic applications tesa® 64286 is a tensitized polypropylene strapping tape with a hot melt adhesive system. It has good tensile strength with low elongation at the same time. The product shows a high peel adhesion.	<ul style="list-style-type: none"> • Pre-material for handylift • Palletizing • Reinforcing • Closing of shipping cartons is also possible 	MOPP	7.5	73	175	35
			Synthetic rubber				



OUTER PACKAGING

Our Products for Outer Packaging Applications

After all the efforts you spend on designing and producing quality products, they should be secured by an efficient and reliable shipping case. Our solutions for outer packaging applications allow you to do both, while offering state-of-the-art packaging features. We provide various solutions for different shipping and storage environments. Solutions for the transportation of shelf-ready packages over standard

carton box sealing up to knifeless opening innovations allow you to find the right packaging tape within our assortment. We also have solutions for securely closing cardboard boxes to be stored in cold temperatures. Especially beneficial is our newest sealing tape, which allows you to open carton boxes without a knife, thus removing the risk of damaging the contents of the box.

CARTON SEALING



Safe Journey, Safe Arrival – Our Assortment Allows That Your Products Reach Their Destination Intact

Secure packaging is the primary requirement for ensuring that a product reaches its destination intact. Whether the carton is light or heavy, traveling a short distance by rail, or taking a long journey by ship, we have developed our current packaging tape range to meet every requirement for the sealing of carton boxes. We provide a wide assortment for carton sealing including tape dispensers that make your packaging efficient and reliable.

Features of carton sealing

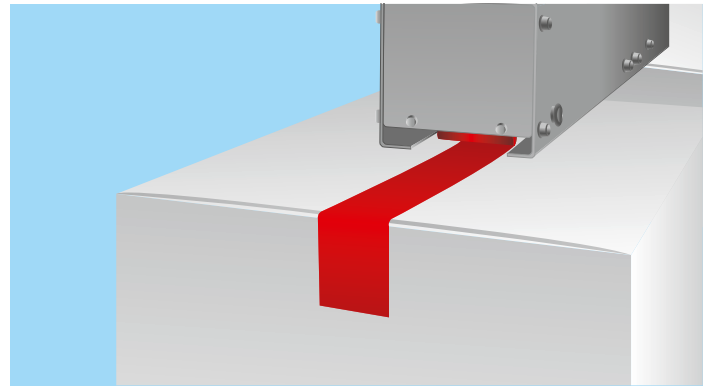
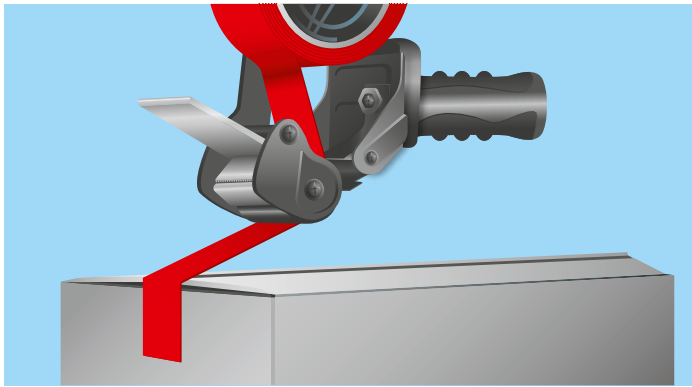
- Manual and automatic sealing of light and medium-range weight cartons
- Easy to unwind and suitable for use in hand dispensers or packaging machines
- A full and complete solution including the tape and a tesa® 6400 dispenser



Tape	Product description and application	Main application	Backing	Adhesion to steel [N/cm]	Total thickness [μm]	Tensile strength [N/cm]	Elongation at break [%]
			Adhesive				
	tesa® 4120 General purpose carton sealing tape tesa® 4120 is a packaging tape based on a PVC film backing and a natural rubber adhesive. tesa® 4120 can be used in manual and automatic sealing equipment.	• tesa® 4120 is used for manual sealing of cartons of medium-range weight	PVC film	2.0	49	43	75
			Natural rubber				
	tesa® 4280 Carton sealing tape tesa® 4280 is a self-adhesive tape based on 25 μm PP-film and a synthetic rubber adhesive. The product is available in 2 colors and is noisy to unwind.	• Manual and automatic sealing of light and medium-range weight cartons	PP film	4.8	42	40	145
			Synthetic rubber				
	tesa® 4313 PVO High performance paper carton sealing tape It can be used for a wide variety of different cardboard qualities. Seals can resist short-term shocks as the elongation of the paper is very high. The product is easy to unwind and suitable for use in hand dispensers or packaging machines.	• Manual and automatic sealing of light and medium-range weight cartons	Paper	7.5	107	50	8
			Synthetic rubber				

Release layer on backing

The unwinding properties are dependent on this layer.

Backing

Provides tear and elongation characteristics.

- Polypropylene (BOPP)
- Polyvinylchloride (PVC)
- Paper

Primer

Responsible for anchorage of adhesive to backing material.

Adhesive

Its shear and adhesion properties are essential for carton closure performance.

- Synthetic rubber (hot-melt)
- Natural rubber
- Water-based acrylic

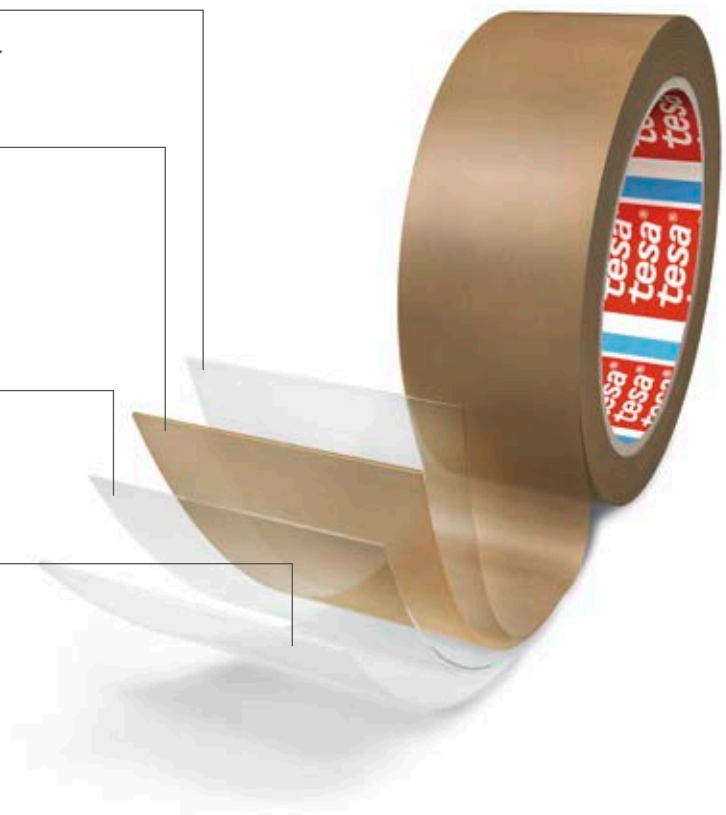

Which is the right carton?

Corrugated quality – the differences

Different weights require different boxes made of different kinds of cardboard. Certainly lightweight and mid to heavy goods are better protected in a double flute or triple flute box, but hazardous goods should be packed in triple flute boxes. (Note: Certain provisions are mandated by regional law!) The following illustrations show the difference between the corrugated qualities:

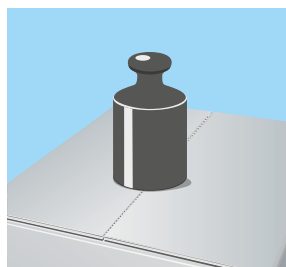

<20 kg single flute
for normal light weights

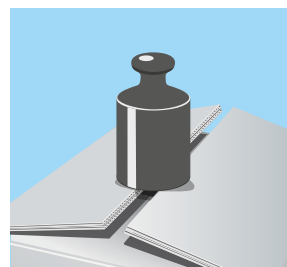

<40 kg double flute
for mid to heavy loads

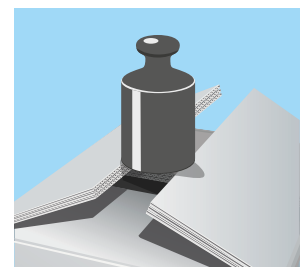

<100 kg triple flute
for extremely heavy loads

Different qualities, different flap pressures

Different cardboard qualities have different flap pressures. The pictures show, from left to right, single flute to triple flute cartons with a 2.0 kg weight on them. The higher the flap pressure, the greater the requirements of the tape.

Paper quality testliner

Testliner is always made entirely from recycled materials. This rough paper has only short fibers, thus making this box less stable when compared to kraftliner.

Kraftliner

Kraftliner is produced not only from recycled materials, but also from new materials, which contain long fibers. These provide optimal stability, but the cardboard is more expensive. You can easily identify the kind of liner by checking the color. Paper made from wood is normally browner.

FROZEN FOOD BOXES

Securing Carton Box Closure in Cold Environment

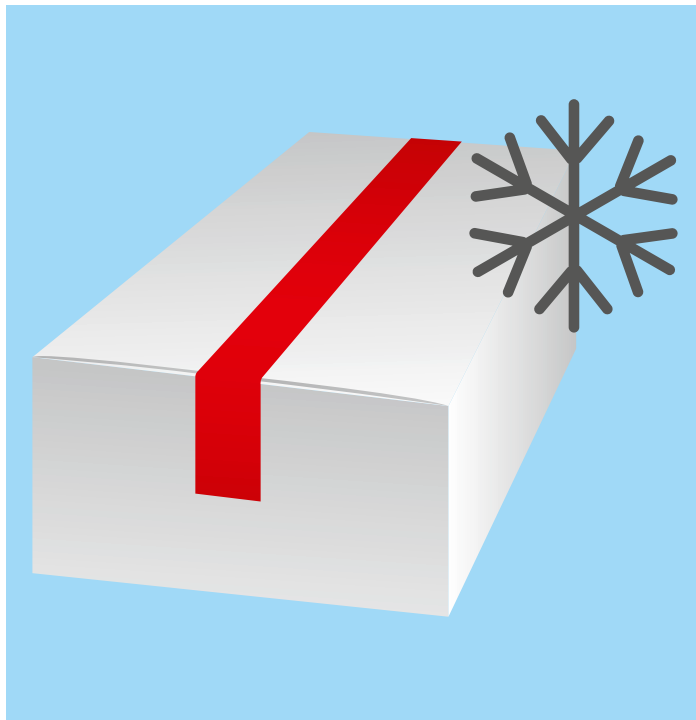

To ensure a strong bond while storing or transporting refrigerated food

Features of frozen food boxes

- Excellent performance on all kinds of cardboard
- Safe closure of medium- and heavy-weight cartons
- Smooth and easy unwinding
- Ideal for use in hand dispensers and automatic sealing equipment

tesa® 4089 PV6

General purpose carton sealing tape

tesa® 4089 PV6 is based on a 28 µm PP backing with a natural rubber adhesive.

Main application

Manual and automatic sealing of light and medium-range weight cartons.

tesa® 4100

General purpose carton sealing tape

tesa® 4100 is based on a PVC backing coated with a natural rubber adhesive. Due to its embossed film texture, even and smooth unwinding is guaranteed. The embossed surface also prevents reflection during e.g. barcode reading, for example; therefore, the product is perfectly suited to label protection.

Main application

tesa® 4100 is used for manual and automatic sealing of cartons of medium range weight.

tesa® 4120

General purpose carton sealing tape

tesa® 4120 is a packaging tape based on a PVC-film backing and a natural rubber adhesive. tesa® 4120 can be used on manual and automatic sealing equipment.

Main application

tesa® 4120 is used for manual sealing of cartons of medium-range weight.

Find the right carton sealing tape for frozen food

Technical properties	tesa® 4089 PV6	tesa® 4100	tesa® 4120	tesa® 4122	tesa® 4124
Tape					
Backing material	PP film	PVC film	PVC film	PVC film	PVC film
Total thickness	46 µm	65 µm	49 µm	88 µm	65 µm
Backing thickness	28 µm	48 µm	30 µm	60 µm	38 µm
Type of adhesive	Natural rubber	Natural rubber	Natural rubber	Natural rubber	Natural rubber
Adhesion to steel	2.2 N/cm	2.2 N/cm	2.0 N/cm	2.0 N/cm	3.2 / 2.3 N/cm*
Elongation at break	145%	75%	75%	100%	60%
Tensile strength	43 N/cm	47 N/cm	43 N/cm	65 N/cm	60 N/cm
Automatic application	Yes	Yes	Yes	Yes	Yes
Printability	No	●●●●	●●●●	●●●●	●●●●
Low noise unwinding	No	Yes	Yes	Yes	Yes
Color	White, havana, transparent	White, havana, transparent	White, havana, transparent	Havana/Chamois, transparent	White, havana, transparent*
Specials	–	–	–	Suitable for dangerous goods <45 kg	Suitable for dangerous goods <15 kg

Evaluation across relevant tesa® assortment: ●●●● Very good ●●● Good ●● Medium ● Low
* tesa® 4124 transparent

tesa® 4122

Heavy duty carton sealing tape

tesa® 4122 is a premium packaging tape based on a very strong PVC backing and a natural rubber adhesive. Even heavy boxes or boxes with multilayer cardboard with high flap tension can be closed safely. External tests have proven that the process of cardboard waste recycling will not be disrupted.

Main application

tesa® 4122 is designed to close very heavy cartons or boxes with hazardous content.

tesa® 4124

Premium general purpose carton sealing tape

tesa® 4124 is a premium packaging tape based on a PVC-film backing and a natural rubber adhesive. It shows excellent performance on all kind of cardboards and secures a safe closure of medium and also heavy-weight cartons. tesa® 4124 unwinds smoothly and noiselessly, which makes it ideal for use in hand dispensers and automatic sealing equipment.

Main application

tesa® 4124 is used for manual and automatic sealing of cartons of medium range weight.



KNIFELESS BOX OPENING

Opening Cartons Without a Knife



Premium products often come with premium packaging. Those being bundled in carton boxes are exposed to a severe danger – the carton box being opened with knives or blades. The premium packaging or even the top layer of the product itself is often damaged by the knives. Our knifeless box opening solution offers reliable and tamper-evident sealing, while being openable by hand. We can provide this solution in different designs and qualities such as easy unwinding long rolls for automatic application units as well as short rolls for smooth manual application in a hand dispenser.

Also use our new knifeless box closing solution in production processes of candies or other consumables to guarantee that residue from the carton box or plastic bag material being cut does not find its way into the process.

Features of knifeless box closure

- Easy opening without any tools
- Avoids cutting into your valuable goods
- No contamination or damage of the inner packaging
- Tamper-evident sealing
- Easy application with our tesa® 6075 hand dispenser

Tape	Product description and application	Adhesive	Adhesion to steel [N/cm]	Total thickness [µm]	Tensile strength [N/cm]	Elongation at break [%]	Additional information
				Backing thickness [µm]			
	tesa® 4190 Knifeless box opening, with fingerlift This solution offers reliable and tamper-evident sealing, while being openable by hand.	Synthetic rubber	4.8	45	43	145	Fingerlift for knifeless opening
				28			

PALLETIZING OF CARTONS

Palletizing Tapes for Shelf-Ready Packaging

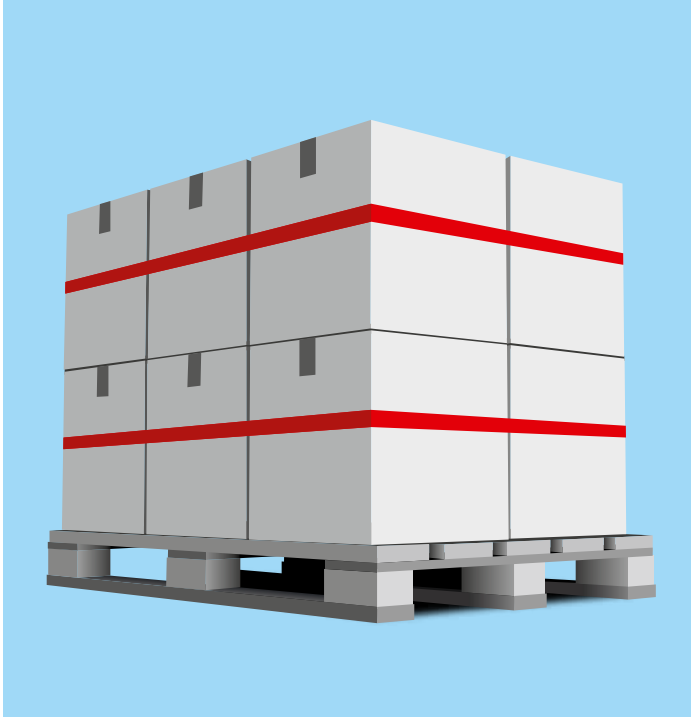

Before loose or packaged goods can be transported, they need to be bundled or palletized. To prevent consignments from slipping, moving, and shifting, especially strong tapes with sturdy backings, allowing only minimal elongation while under pressure from mechanical and environmental stress, are needed. In addition, excellent adhesion is required in order to make sure the tape stays in place on a variety of substrates, ranging from cardboard, metal, and plastics, to difficult surfaces such as shrink-wraps and protective films.

Features of palletizing

- Securing of pallets with printed or labeled carton boxes
- Does not damage the surface after its removal
- Barcode readable during picking and packing due to translucent backing

Tape	Product description and application	Backing	Adhesion to steel [N/cm]	Total thickness [µm]	Tensile strength [N/cm]	Elongation at break [%]	Color
		Adhesive					
	tesa® 51128 Soft tensilized polypropylene tesa® 51128 is a tensilized polypropylene strapping tape with a special solvent-free natural rubber adhesive system. tesa® 51128 does not damage the surfaces of typical printed or labeled carton boxes after its removal.	MOPP	1.0	60	106	30	O Trans- parent
		Natural rubber					



DISPENSER

With tesa® Dispensers Your Production Processes Will Be Optimized

As a world leading supplier of self-adhesive products and solutions, we offer you a large variety of tapes and at the same time assist your working processes with professional dispensers that match tesa® tapes perfectly. These were developed by collaborating with users, making them work-

place friendly and suitable for perfect working ergonomics. Our Application Solution Center's dedicated experts are always ready to help you with any application-related question or problem.

DISPENSER FOR BAG SEALING

Bag Sealing Tapes That Close Paper and Plastic Bags Securely



tesa® 6094

Bag sealing dispenser

Any plastic or paper bag with a twisted neck diameter of up to 11 mm can be sealed effectively using the tesa® 6094 bag sealer. Recommended tesa® products: filmic tape, tesa® 4104 or paper tape, tesa® 4328.

Technical properties	tesa® 6094
Core diameter	3 inch
Type of tape	Single-sided
Length	210 mm
Width	85 mm
Height	205 mm
Mode of drive	Manual
Weight	1350 g
Max. roll diameter	170 mm
Type of applicator	Table
Max. roll width	19 mm



tesa® 6256

Bag sealing dispenser

Any plastic or paper bag with a twisted neck diameter of up to 6 mm can be sealed effectively using the tesa® 6256 bag sealer. Recommended tesa® products: filmic tapes, tesa® 4104 or 4205; paper tape, tesa® 4328.

Technical properties	tesa® 6256
Core diameter	3 inch
Type of tape	Single-sided
Length	185 mm
Width	70 mm
Height	270 mm
Mode of drive	Manual
Weight	610 g
Max. roll diameter	130 mm
Type of applicator	Table
Max. roll width	12 mm

DISPENSER FOR CARTON SEALING

Safe Journey, Safe Arrival – Our Assortment Allows
That Your Products Reach Their Destination Intact



tesa® 6005

Professional packaging hand dispenser

The tesa® 6005's system of 2 application rollers offers easy handling and special blade protection for safety. The tape is cut by pressing the trigger on the handle. The dispenser is equipped with a continuously adjustable tension control. The brake can be tightened when tight "strapping" of the tape around a package is desired.

Technical properties	tesa® 6005
Core diameter	3 inch
Length	220 mm
Width	45 mm
Height	210 mm
Weight	530 g
Max. roll diameter	170 mm
Type of applicator	Hand
Max. roll width	25 mm



tesa® 6075

Professional packaging hand dispenser

The tesa® 6075 hand dispenser is a robust industrial device that takes tesa® packaging tapes up to 75 mm wide. Its system of 2 application rollers offers easy handling and special blade protection for safety. The tape is cut by pressing the trigger on the handle. The continuously adjustable tension control allows correct dispensing, even of easy to unwind tesa® tapes. The soft gummed handle ensures a secure and comfortable grip.

Technical properties	tesa® 6075
Core diameter	3 inch
Length	210 mm
Width	90 mm
Height	210 mm
Weight	690 g
Max. roll diameter	170 mm
Type of applicator	Hand
Max. roll width	75 mm

tesa® 6300



Professional packaging hand dispenser

The tesa® 6300 hand dispenser is a robust industrial device that takes tesa® packaging tapes up to 50 mm wide. Its system of 2 application rollers offers easy handling and special blade protection for safety. The tape is cut by pressing the trigger on the handle. The continuously adjustable tension control allows correct dispensing, even of easy to unwind tesa® tapes. The soft gummed handle ensures a secure and comfortable grip.

Technical properties	tesa® 6300
Core diameter	3 inch
Length	150 mm
Width	65 mm
Height	240 mm
Weight	350 g
Max. roll diameter	120 mm
Type of applicator	Hand
Max. roll width	50 mm

tesa® 6400



Dispenser COMFORT for packaging tapes

The tesa® 6400 hand dispenser is a robust industrial device that applies tesa® tapes up to 50 mm wide. Its system of a covered blade provides special injury protection (blade protection). The tape is cut by pressing the flap on the tape while the serrated cutting blade will “pop out” to cut the tape. The continuously adjustable tension control allows correct dispensing, even of easy unwinding tesa® tapes. tesa® 6400 has a soft gummed handle, which ensures a comfortable and secure grip.

Technical properties	tesa® 6400
Core diameter	3 inch
Length	220 mm
Width	60 mm
Height	220 mm
Weight	500 g
Max. roll diameter	140 mm
Type of applicator	Hand
Max. roll width	50 mm

tesa® 56402



Packaging hand dispenser superior snapshot 50

The tesa® 56402 hand dispenser is a robust industrial device that takes tesa® tapes up to 50 mm wide. Its system of 2 application rollers offers easy handling and special injury protection (blade protection). The tape is cut by pressing the trigger on the handle. The continuously adjustable tension control allows correct dispensing, even of easy to unwind tesa® tapes. The soft gummed handle ensures a secure and comfortable grip.

Technical properties	tesa® 56402
Core diameter	3 inch
Length	205 mm
Width	65 mm
Height	205 mm
Weight	665 g
Max. roll diameter	170 mm
Type of applicator	Hand
Max. roll width	50 mm

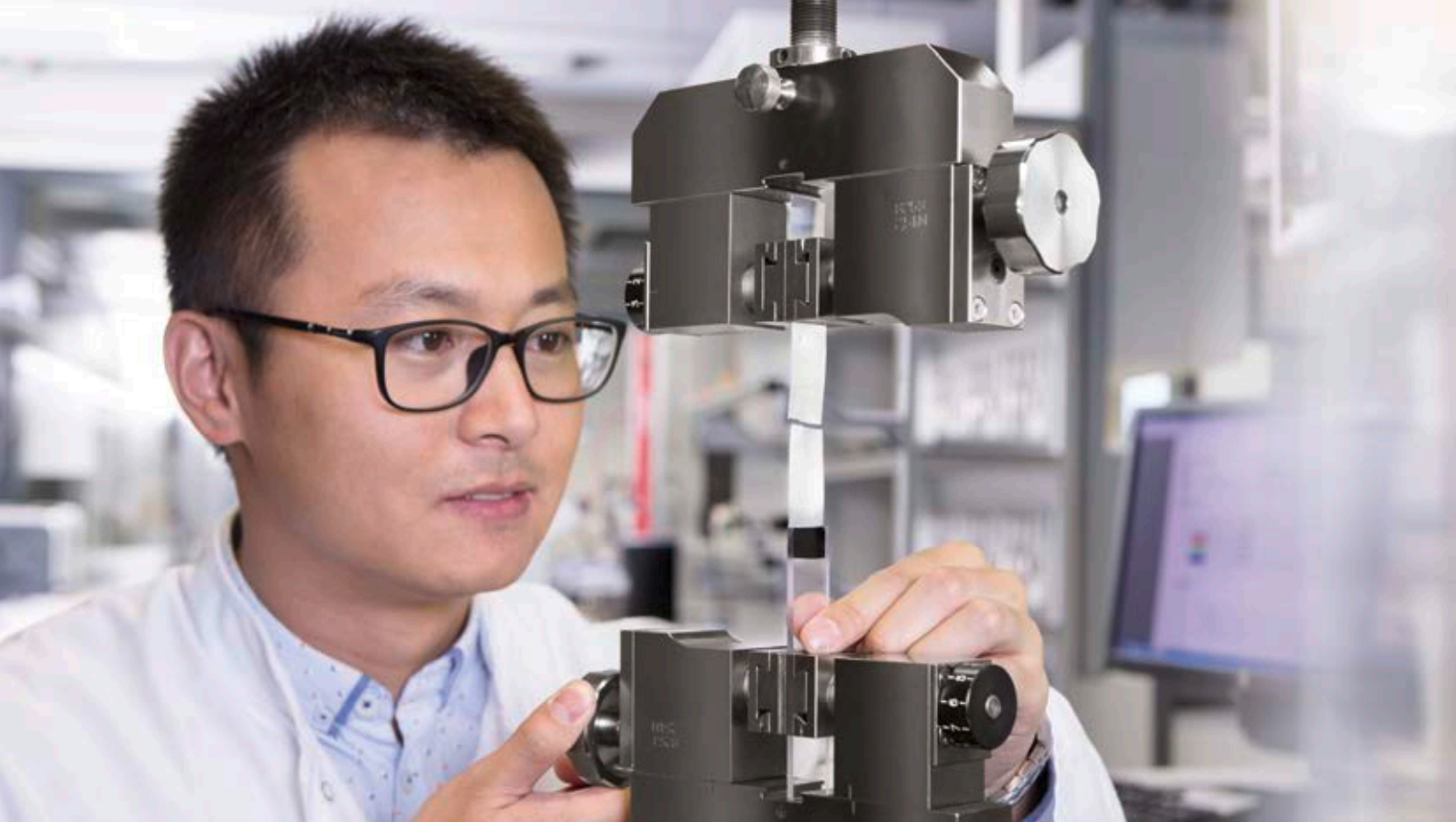

APPLICATION SOLUTION CENTER

Technical Customer Service Is Our Top Priority

We offer you a wide range of products supporting you in all of your business fields. Many options often require a closer look into the specific application. Here we can support you by taking into account the customers' materials, their application process, and the operating conditions for the product in use.

From a range of several hundred adhesive tape solutions, we select the right product for your customers' application while considering their specific requirements.

In our Application Solution Centers we analyze customers' materials, in combination with our adhesive tape products, depending on the application-specific demands, such as bonding power, shock absorption, resistance to environmental impacts, removability, and much more.

During on-site visits, we assist you in detecting such requirements and translate those into appropriate test programs.

Not only do we recommend the suitable products, we also support the implementation stage of our solutions into your customers' process with application tools and equipment.

Based on our modular training program, we individually teach you and your customers about the adhesive tape technology, along with our products, their applications, and corresponding tools. This can either be done at our technical training facilities or even as on-site training on your premises.

Our global network of application engineers collaborate closely to provide short response times and close customer contact, offering you many years of experience and expertise in adhesive tape products and applications.

Our Sales team will assist you in directing your inquiries to our Application Solution Centers.

WORLDWIDE PRESENCE

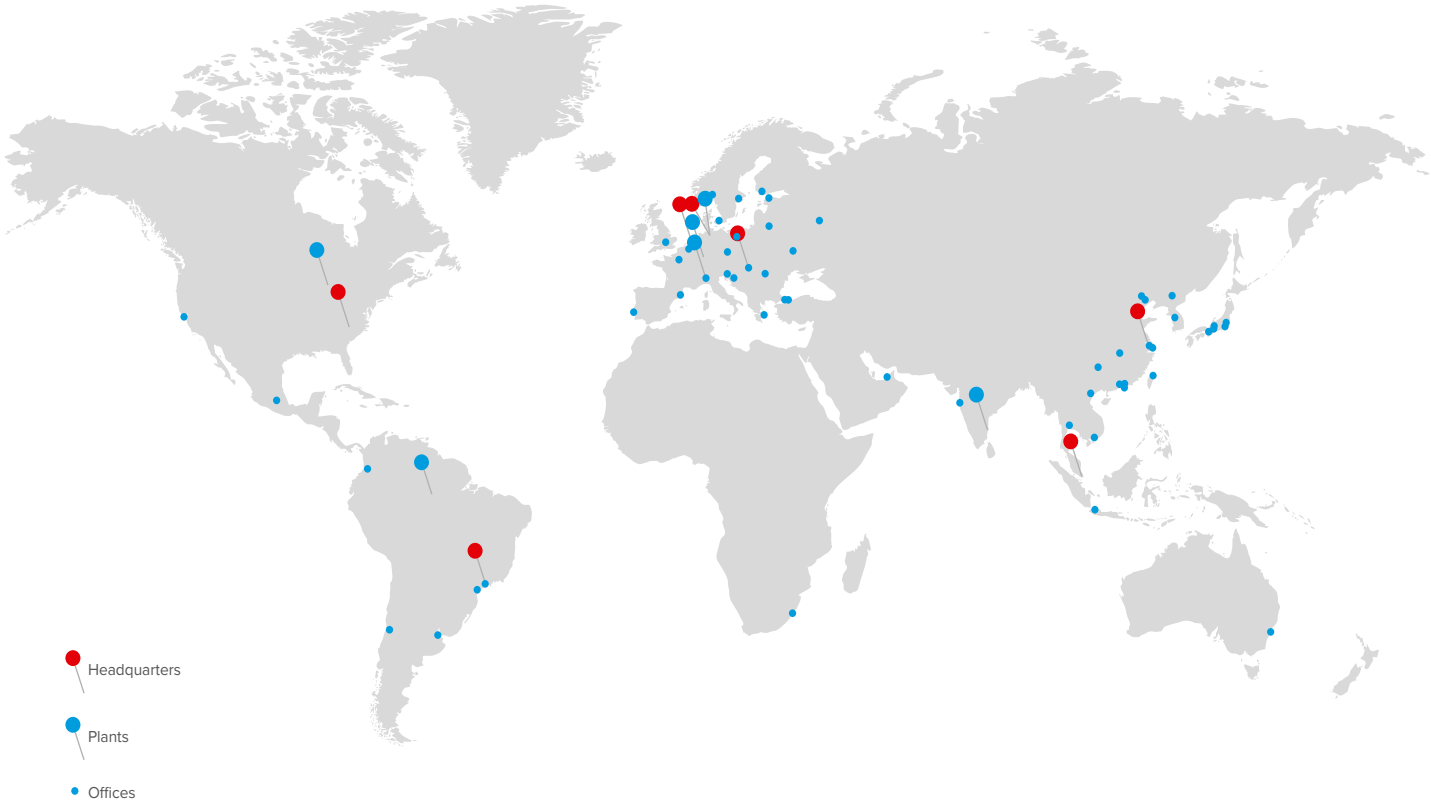

tesa® products prove their impressive quality day in, day out in demanding conditions and are regularly subjected to strict controls. All technical information and data above mentioned are provided to the best of our knowledge on the basis of our practical experience. They shall be considered as average values and are not appropriate for a specification. Therefore tesa SE can make no warranties, express or implied, including, but not limited to any implied warranty of merchantability or fitness for a particular purpose. The user is responsible for determining whether the tesa® product is fit for a particular purpose and suitable for the user's method of application. If you are in any doubt, our technical support staff will be glad to support you.



Our management system is certified according to the standards ISO 9001, ISO/TS 16949, and ISO 14001.